

ACBMV B. CASADIO VIBRATION  
 Z.I. Mi-Plaine  
 51 Rue Ampère  
 B.P. 31  
 69682 CHASSIEU CEDEX (FRANCE)  
 Tel.: 04 78 90 87 87 / Fax.: 04 78 90 87 88  
 Email: [vibrateur@orange.fr](mailto:vibrateur@orange.fr)  
 Internet: [acbmv.com](http://acbmv.com)

8 POLES - 900 RPM  
 REF.: 602576C  
 SIZE: 20

Certifications:



### MECHANICAL AND ELECTRICAL SPECIFICATIONS

Eccentric weight setup (%)	Static moment (kgmm)	Working moment (kgcm)	Centrifugal force (kg)	Centrifugal force (kN)	Estimated bearings life time (hours)
100	163	32,60	149	1,46	>100000
90	146,70	29,34	134	1,31	>100000
80	130,40	26,08	119	1,17	>100000
70	114,10	22,82	104	1,02	>100000
60	97,80	19,56	89	0,88	>100000
50	81,50	16,30	75	0,73	>100000
40	65,20	13,04	60	0,58	>100000
30	48,90	9,78	45	0,44	>100000
20	32,60	6,52	30	0,29	>100000
10	16,30	3,26	15	0,15	>100000

Power supply (volts)	460
Phases:	three phases
Frequency (Hz)	60 Hz
Rotation speed (RPM)	900
Max input power (watt)	Input: 250 Rating: 120
Max current (amp)	0,76
IS/IR	2,11

### DIMENSIONAL SPECIFICATIONS (mm)

**Vibrator weight: 21,4 kg**

Continual service ambient temperature: -20°C à +40°C - Tropicalization anti-mold - Mechanical protection: IP66 IK08 according to IEC

Bearing type: BALL

Lubrication "FOR LIFE" with double protection screen

Fixing with 4 screws M12 - 1/2" quality 8.8 with tightening torque (kgm - ft/lb): 8 - 58

- Thread (pipe thread not supplied): NPT1/2"

Maintenance space: 96 mm

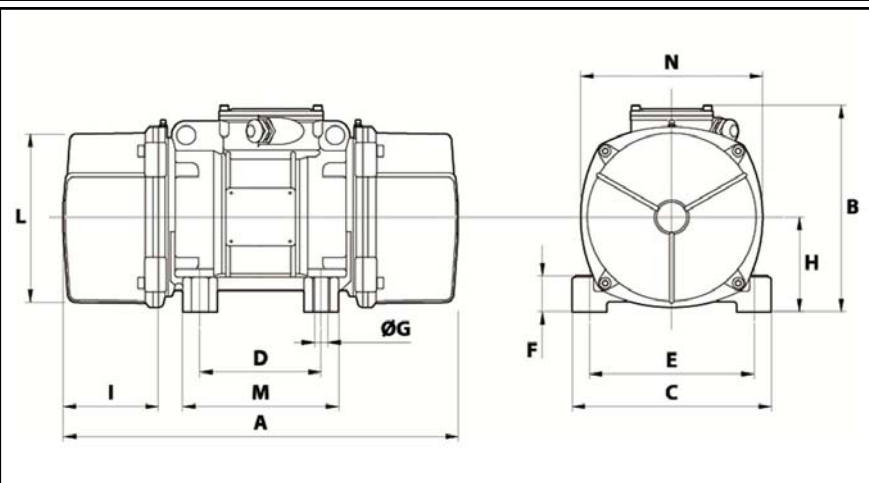

A	350
B	218
C	167
D	105
E	140
F	30
G	13
N° HOLES	4
H	90
I	96
L	150
M	140
N	175