

ACBMV B. CASADIO VIBRATION
 Z.I. Mi-Plaine
 51 Rue Ampère
 B.P. 31
 69682 CHASSIEU CEDEX (FRANCE)
 Tel.: 04 78 90 87 87 / Fax.: 04 78 90 87 88
 Email: vibrateur@orange.fr
 Internet: acbm.com

8 POLES - 750 RPM
 REF.: 602617A
 SIZE: 30

Certifications:



MECHANICAL AND ELECTRICAL SPECIFICATIONS

Eccentric weight setup (%)	Static moment (kgmm)	Working moment (kgcm)	Centrifugal force (kg)	Centrifugal force (kN)	Estimated bearings life time (hours)
100	286	57,20	181	1,76	>100000
90	257,40	51,48	163	1,58	>100000
80	228,80	45,76	145	1,41	>100000
70	200,20	40,04	127	1,23	>100000
60	171,60	34,32	109	1,06	>100000
50	143,00	28,60	91	0,88	>100000
40	114,40	22,88	72	0,70	>100000
30	85,80	17,16	54	0,53	>100000
20	57,20	11,44	36	0,35	>100000
10	28,60	5,72	18	0,18	>100000

Power supply (volts)	400
Phases:	three phases
Frequency (Hz)	50 Hz
Rotation speed (RPM)	750
Max input power (watt)	350
Max current (amp)	1,1
IS/IR	2,29

DIMENSIONAL SPECIFICATIONS (mm)

Vibrator weight: 32 kg

Continual service ambient temperature: -20°C à +40°C - Tropicalization anti-mold - Mechanical protection: IP66 IK08 according to IEC

Bearing type: BALL

Lubrication "FOR LIFE" with double protection screen

Fixing with 4 screws M16 - 5/8" quality 8.8 with tightening torque (kgm - ft/lb): 19 - 137

Power supply cable size: 9 à 16 mm - Cable entry thread: M25x1,5

Maintenance space: 98 mm

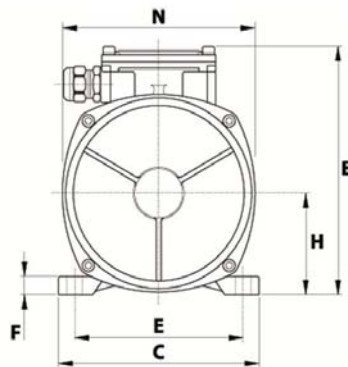

A	378
B	205
C	205
D	120
E	170
F	17
G	17
N° HOLES	4
H	93,5
I	98
L	168
M	160
N	182
