

ACBMV B. CASADIO VIBRATION
 Z.I. Mi-Plaine
 51 Rue Ampère
 B.P. 31
 69682 CHASSIEU CEDEX (FRANCE)
 Tel.: 04 78 90 87 87 / Fax.: 04 78 90 87 88
 Email: vibrateur@orange.fr
 Internet: acbm.com

6000 RPM
 REF.: 6030100
 SIZE: AF68
 Certifications:



MECHANICAL AND ELECTRICAL SPECIFICATIONS

Eccentric weight setup (%)	Centrifugal force (kg)	Centrifugal force (kN)	Estimated bearings life time (hours)
100	2800	27,5	439
90	2520	24,75	624
80	2240	22,00	924
70	1960	19,25	1441
60	1680	16,50	2410
50	1400	13,75	4425
40	1120	11,00	9310
30	840	8,25	24288
20	560	5,50	93835
10	280	2,75	>100000

Power supply (volts)	250
Phases:	three phases
Frequency (Hz)	100 Hz
Rotation speed (RPM)	6000
Max input power (watt)	4000
Max current (amp)	11
IS/IR	5,1

DIMENSIONAL SPECIFICATIONS (mm)

Vibrator weight: 74 kg

Continual service ambient temperature: -20°C à +40°C - Tropicalization anti-mold - Mechanical protection: IP66 IK08 according to IEC

Bearing type: ROLLER

Lubrication LONG-LIFE with KLUEBER ISOFLEX NBU 15.

Re lubrication quantity after 1000 hours of using: 9g

Max quantity by replaced bearing: 16g

Fixing with 4 screws M22 - 7/8" quality 8.8 with tightening torque (kgm - ft/lb): 56 - 411

Power supply cable size: 9 à 16 mm - Cable entry thread: M25x1,5

Maintenance space: 147 mm

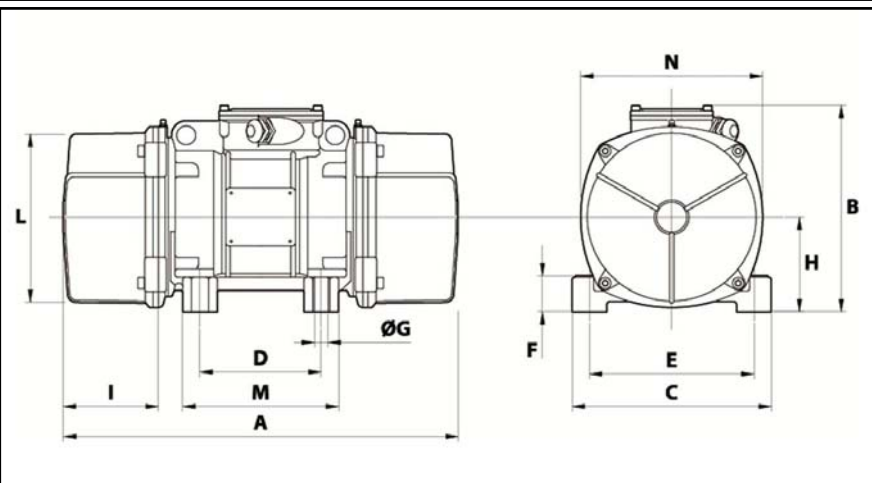

A	528
B	267
C	310
D	155
E	255
F	122
G	23,5
N° HOLES	4
H	115
I	147
L	265
M	215
N	275
