

ACBMV B. CASADIO VIBRATION  
 Z.I. Mi-Plaine  
 51 Rue Ampère  
 B.P. 31  
 69682 CHASSIEU CEDEX (FRANCE)  
 Tel.: 04 78 90 87 87 / Fax.: 04 78 90 87 88  
 Email: [vibrateur@orange.fr](mailto:vibrateur@orange.fr)  
 Internet: [acbm.com](http://acbm.com)

6000 RPM  
 REF.: 603037Q  
 SIZE: AF50  
 Certifications:



### MECHANICAL AND ELECTRICAL SPECIFICATIONS

Eccentric weight setup (%)	Centrifugal force (kg)	Centrifugal force (kN)	Estimated bearings life time (hours)
100	1978	19,4	1399
90	1780	17,46	1988
80	1582	15,52	2943
70	1385	13,58	4594
60	1187	11,64	7679
50	989	9,70	14101
40	791	7,76	29668
30	593	5,82	77401
20	396	3,88	>100000
10	198	1,94	>100000

Power supply (volts)	250
Phases:	three phases
Frequency (Hz)	200 Hz
Rotation speed (RPM)	6000
Max input power (watt)	2000
Max current (amp)	5,9
IS/IR	8

### DIMENSIONAL SPECIFICATIONS (mm)

**Vibrator weight: 40 kg**

Continual service ambient temperature: -20°C à +40°C - Tropicalization anti-mold - Mechanical protection: IP66 IK08 according to IEC

Bearing type: ROLLER

Lubrication LONG-LIFE with KLUEBER ISOFLEX NBU 15.

Re lubrication quantity after 1000 hours of using: 9g

Max quantity by replaced bearing: 16g

Fixing with 4 screws M16 - 5/8" quality 8.8 with tightening torque (kgm - ft/lb): 19 - 137

Power supply cable size: 9 à 16 mm - Cable entry thread: M25x1,5

Maintenance space: 87,5 mm

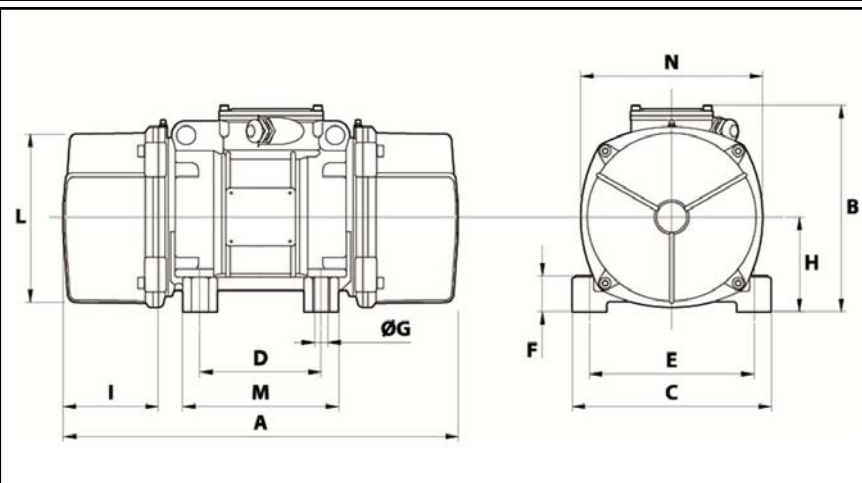

A	430
B	230
C	230
D	140
E	190
F	49
G	17
N° HOLES	4
H	104
I	87,5
L	186
M	180
N	200
