

ACBMV B. CASADIO VIBRATION  
 Z.I. Mi-Plaine  
 51 Rue Ampère  
 B.P. 31  
 69682 CHASSIEU CEDEX (FRANCE)  
 Tel.: 04 78 90 87 87 / Fax.: 04 78 90 87 88  
 Email: [vibrateur@orange.fr](mailto:vibrateur@orange.fr)  
 Internet: [acbmv.com](http://acbmv.com)

6000 RPM  
 REF.: 6030440  
 SIZE: AF30  
 Certifications:



### MECHANICAL AND ELECTRICAL SPECIFICATIONS

Eccentric weight setup (%)	Centrifugal force (kg)	Centrifugal force (kN)	Estimated bearings life time (hours)
100	1022	9,7	1947
90	920	8,73	2766
80	818	7,76	4096
70	715	6,79	6393
60	613	5,82	10687
50	511	4,85	19625
40	409	3,88	41289
30	307	2,91	>100000
20	204	1,94	>100000
10	102	0,97	>100000

Power supply (volts)	250
Phases:	three phases
Frequency (Hz)	100 Hz
Rotation speed (RPM)	6000
Max input power (watt)	1000
Max current (amp)	3,7
IS/IR	6,06

### DIMENSIONAL SPECIFICATIONS (mm)

**Vibrator weight: 18 kg**

Continual service ambient temperature: -20°C à +40°C - Tropicalization anti-mold - Mechanical protection: IP66 IK08 according to IEC

Bearing type: ROLLER

Lubrication LONG-LIFE with KLUEBER ISOFLEX NBU 15.

Re lubrication quantity after 1000 hours of using: 4g

Max quantity by replaced bearing: 8g

Fixing with 4 screws M12 - 1/2" quality 8.8 with tightening torque (kgm - ft/lb): 8 - 58

Power supply cable size: 9 à 16 mm - Cable entry thread: M25x1,5

Maintenance space: 54 mm

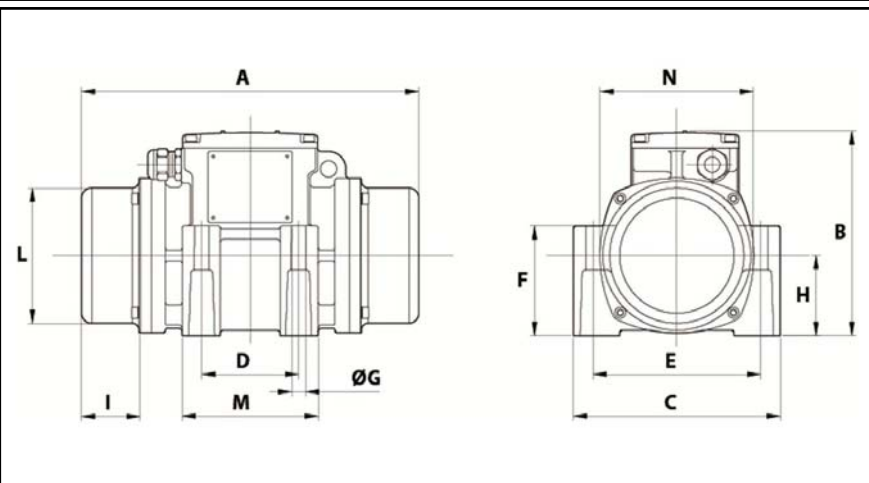

A	310
B	186
C	190
D	90
E	154
F	100
G	13
N° HOLES	4
H	73
I	54
L	124
M	125
N	141
