

ACBMV B. CASADIO VIBRATION
 Z.I. Mi-Plaine
 51 Rue Ampère
 B.P. 31
 69682 CHASSIEU CEDEX (FRANCE)
 Tel.: 04 78 90 87 87 / Fax.: 04 78 90 87 88
 Email: vibrateur@orange.fr
 Internet: acbmv.com

6000 RPM
 REF.: 603050Q
 SIZE: AF10

Certifications:



MECHANICAL AND ELECTRICAL SPECIFICATIONS

Eccentric weight setup (%)	Centrifugal force (kg)	Centrifugal force (kN)	Estimated bearings life time (hours)
100	610	5,98	224
90	549	5,38	307
80	488	4,78	438
70	427	4,19	653
60	366	3,59	1037
50	305	2,99	1792
40	244	2,39	3500
30	183	1,79	8296
20	122	1,20	28000
10	61	0,60	>100000

Power supply (volts)	250
Phases:	three phases
Frequency (Hz)	200 Hz
Rotation speed (RPM)	6000
Max input power (watt)	500
Max current (amp)	1,6
IS/IR	4,5

DIMENSIONAL SPECIFICATIONS (mm)

Vibrator weight: 8 kg

Continual service ambient temperature: -20°C à +40°C - Tropicalization anti-mold - Mechanical protection: IP66 IK08 according to IEC

Bearing type: BALL

Lubrication "FOR LIFE" with double protection screen

Fixing with 4 screws M8 - 5/16" quality 8.8 with tightening torque (kgm - ft/lb): 2,30 - 16,50

Power supply cable size: 6,5 à 12 mm - Cable entry thread: M20x1,5

Maintenance space: 54 mm

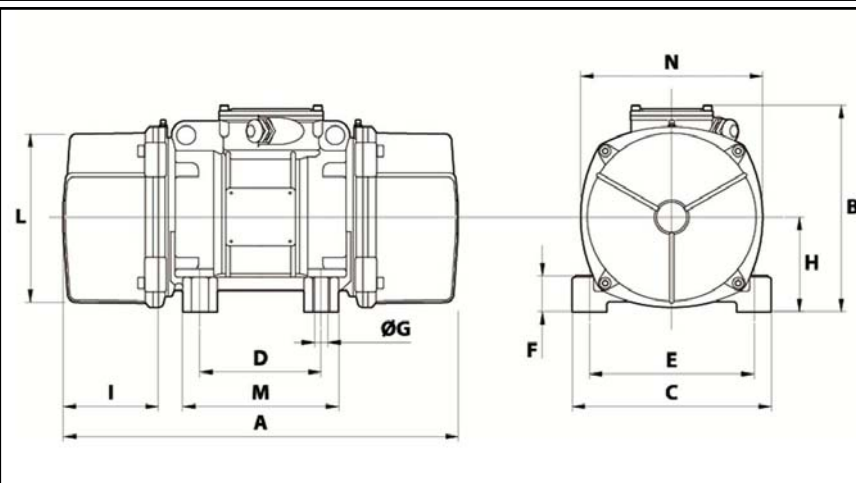

A	255
B	179
C	152
D	90
E	125
F	28
G	13
N° HOLES	4
H	73
I	54
L	124
M	128
N	141
