

ACBMV B. CASADIO VIBRATION
 Z.I. Mi-Plaine
 51 Rue Ampère
 B.P. 31
 69682 CHASSIEU CEDEX (FRANCE)
 Tel.: 04 78 90 87 87 / Fax.: 04 78 90 87 88
 Email: vibrateur@orange.fr
 Internet: acbm.com

6000 RPM
 REF.: 6030530
 SIZE: AF33
 Certifications:



MECHANICAL AND ELECTRICAL SPECIFICATIONS

Eccentric weight setup (%)	Centrifugal force (kg)	Centrifugal force (kN)	Estimated bearings life time (hours)
100	1095	10,7	2253
90	986	9,63	3091
80	876	8,56	4400
70	767	7,49	6569
60	657	6,42	10431
50	548	5,35	18024
40	438	4,28	35203
30	329	3,21	83444
20	219	2,14	>100000
10	110	1,07	>100000

Power supply (volts)	250
Phases:	three phases
Frequency (Hz)	100 Hz
Rotation speed (RPM)	6000
Max input power (watt)	1200
Max current (amp)	3,9
IS/IR	6,04

DIMENSIONAL SPECIFICATIONS (mm)

Vibrator weight: 23 kg

Continual service ambient temperature: -20°C à +40°C - Tropicalization anti-mold - Mechanical protection: IP66 IK08 according to IEC

Bearing type: BALL

Lubrication "FOR LIFE" with double protection screen

Fixing with 4 screws M16 - 5/8" quality 8.8 with tightening torque (kgm - ft/lb): 19 - 137

Power supply cable size: 9 à 16 mm - Cable entry thread: M25x1,5

Maintenance space: 63 mm

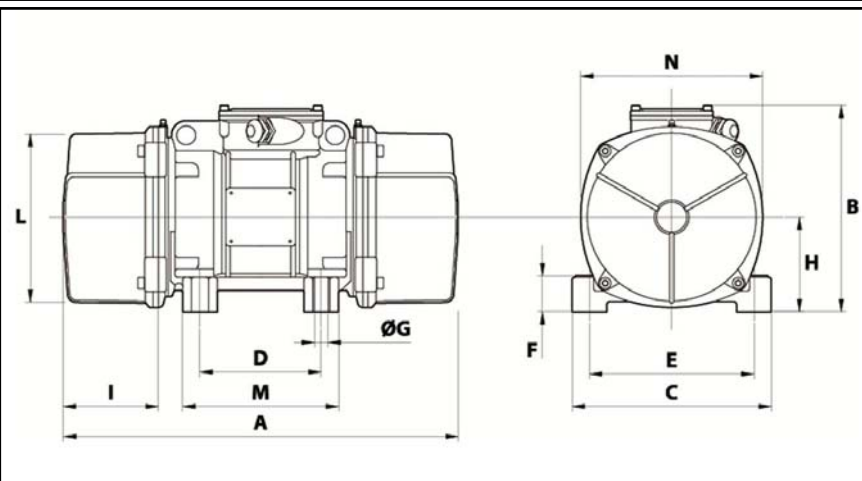

A	289
B	216,5
C	215
D	100
E	180
F	47
G	17
N° HOLES	4
H	93,5
I	63
L	170
M	145
N	182