

ACBMV B. CASADIO VIBRATION  
 Z.I. Mi-Plaine  
 51 Rue Ampère  
 B.P. 31  
 69682 CHASSIEU CEDEX (FRANCE)  
 Tel.: 04 78 90 87 87 / Fax.: 04 78 90 87 88  
 Email: [vibrateur@orange.fr](mailto:vibrateur@orange.fr)  
 Internet: [acbmv.com](http://acbmv.com)

9000 RPM  
 REF.: 604041U  
 SIZE: AF33

Certifications:



### MECHANICAL AND ELECTRICAL SPECIFICATIONS

Eccentric weight setup (%)	Centrifugal force (kg)	Centrifugal force (kN)	Estimated bearings life time (hours)
100	1230	12	1709
90	1107	10,80	2344
80	984	9,60	3338
70	861	8,40	4983
60	738	7,20	7912
50	615	6,00	13672
40	492	4,80	26703
30	369	3,60	63296
20	246	2,40	>100000
10	123	1,20	>100000

Power supply (volts)	42
Phases:	three phases
Frequency (Hz)	150 Hz
Rotation speed (RPM)	9000
Max input power (watt)	1150
Max current (amp)	18
IS/IR	8,52

### DIMENSIONAL SPECIFICATIONS (mm)

**Vibrator weight: 22 kg**

Continual service ambient temperature: -20°C à +40°C - Tropicalization anti-mold - Mechanical protection: IP66 IK08 according to IEC

Bearing type: BALL

Lubrication "FOR LIFE" with double protection screen

Fixing with 4 screws M16 - 5/8" quality 8.8 with tightening torque (kgm - ft/lb): 19 - 137

Power supply cable size: 9 à 16 mm - Cable entry thread: M25x1,5

Maintenance space: 63 mm

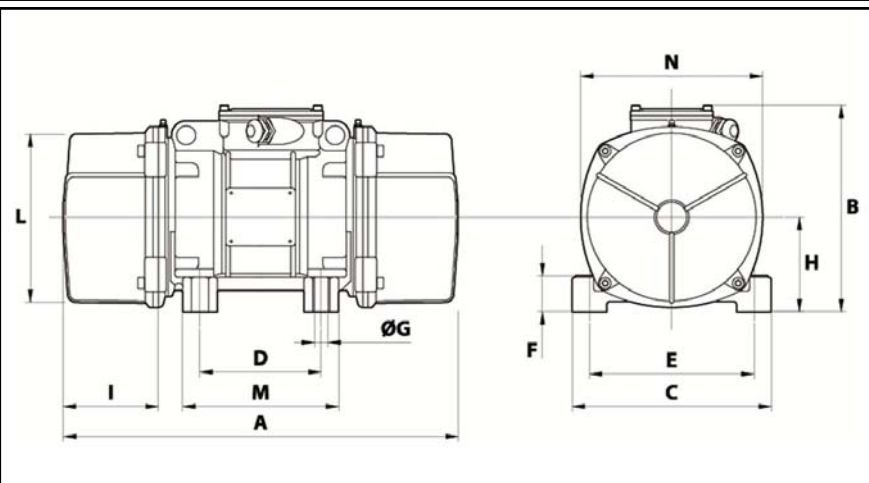

A	289
B	216,5
C	215
D	100
E	180
F	47
G	17
N° HOLES	4
H	93,5
I	63
L	170
M	145
N	182