

ACBMV B. CASADIO VIBRATION
 Z.I. Mi-Plaine
 51 Rue Ampère
 B.P. 31
 69682 CHASSIEU CEDEX (FRANCE)
 Tel.: 04 78 90 87 87 / Fax.: 04 78 90 87 88
 Email: vibrateur@orange.fr
 Internet: acbmv.com

9000 RPM
 REF.: 604042P
 SIZE: AF33
 Certifications:



MECHANICAL AND ELECTRICAL SPECIFICATIONS

Eccentric weight setup (%)	Centrifugal force (kg)	Centrifugal force (kN)	Estimated bearings life time (hours)
100	1484	14,6	655
90	1336	13,14	898
80	1187	11,68	1279
70	1039	10,22	1910
60	890	8,76	3032
50	742	7,30	5240
40	594	5,84	10234
30	445	4,38	24259
20	297	2,92	81875
10	148	1,46	>100000

Power supply (volts)	250
Phases:	three phases
Frequency (Hz)	150 Hz
Rotation speed (RPM)	9000
Max input power (watt)	1600
Max current (amp)	4
IS/IR	10,4

DIMENSIONAL SPECIFICATIONS (mm)

Vibrator weight: 24 kg

Continual service ambient temperature: -20°C à +40°C - Tropicalization anti-mold - Mechanical protection: IP66 IK08 according to IEC

Bearing type: BALL

Lubrication "FOR LIFE" with double protection screen

Fixing with 4 screws M16 - 5/8" quality 8.8 with tightening torque (kgm - ft/lb): 19 - 137

Power supply cable size: 9 à 16 mm - Cable entry thread: M25x1,5

Maintenance space: 106 mm

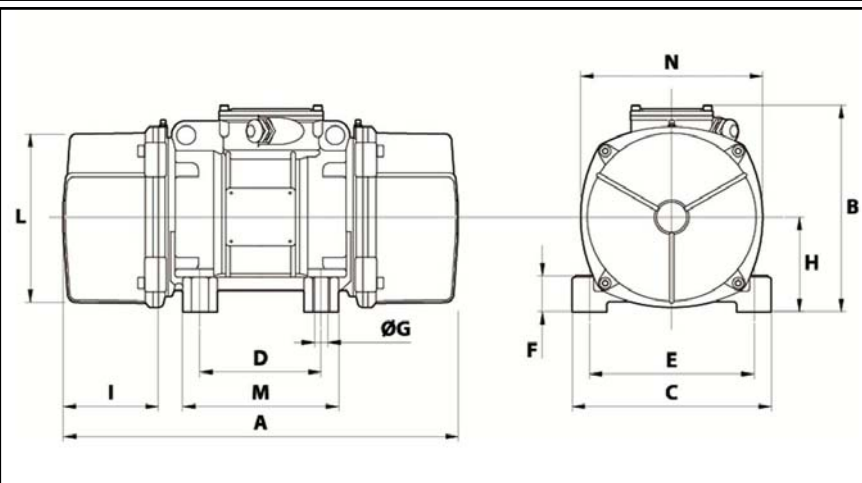

A	375
B	216,5
C	215
D	100
E	180
F	47
G	17
N° HOLES	4
H	93,5
I	106
L	170
M	145
N	182