

VIBRATOR TYPE: MTF 3/500E-S02 260/460 VOLTS THREE PHASES 60 Hz

ACBMV B. CASADIO VIBRATION
 Z.I. Mi-Plaine
 51 Rue Ampère
 B.P. 31
 69682 CHASSIEU CEDEX (FRANCE)
 Tel.: 04 78 90 87 87 / Fax.: 04 78 90 87 88
 Email: vibrateur@orange.fr
 Internet: acbm.com

2 POLES - 3600 RPM ATEX II 2G,D - Classe Ex e II T4/T3 tD A21 IP 66 ZONE 1-2 / 21-22
 REF.: 6E0378C Gas T°=T3-T4 Dust T°=120°C
 SIZE: 20

Certifications:



MECHANICAL AND ELECTRICAL SPECIFICATIONS

Eccentric weight setup (%)	Centrifugal force weight up/down (kg)	Static moment weight	Centrifugal force weight up/down (kN)	Static moment weight up (kgmm)	Estimated bearings life time (hours)
100	235/235	16,2	2,31/2,31	16,2	8500
90	211,5/211,5	14,58	2,08/2,08	14,58	11660
80	188/188	12,96	1,85/1,85	12,96	16602
70	164,5/164,5	11,34	1,62/1,62	11,34	24781
60	141/141	9,72	1,39/1,39	9,72	39352
50	117,5/117,5	8,10	1,16/1,16	8,10	68000
40	94/94	6,48	0,92/0,92	6,48	>100000
30	70,5/70,5	4,86	0,69/0,69	4,86	>100000
20	47/47	3,24	0,46/0,46	3,24	>100000
10	23,5/23,5	1,62	0,23/0,23	1,62	>100000

Power supply (volts)	460
Phases:	three phases
Frequency (Hz)	60 Hz
Rotation speed (RPM)	3600
Max input power (watt)	Input: T3=500 T4=360 Rating: T3=300 T4=210
Max current (amp)	T3=0,67 T4=0,5
IS/IR	T3=4,2 T4=5,6

DIMENSIONAL SPECIFICATIONS (mm)

Vibrator weight: 14,1 kg

Continual service ambient temperature: -20°C à +40°C - Tropicalization anti-mold - Mechanical protection: IP66 IK08 according to IEC

Bearing type: BALL

Lubrication "FOR LIFE" with double protection screen

Fixing with 6 screws M10 - 7/16" quality 8.8 with tightening torque (kgm - ft/lb): 4.80 - 35

Power supply cable size: 9 à 16 mm - Cable entry thread: M25x1,5

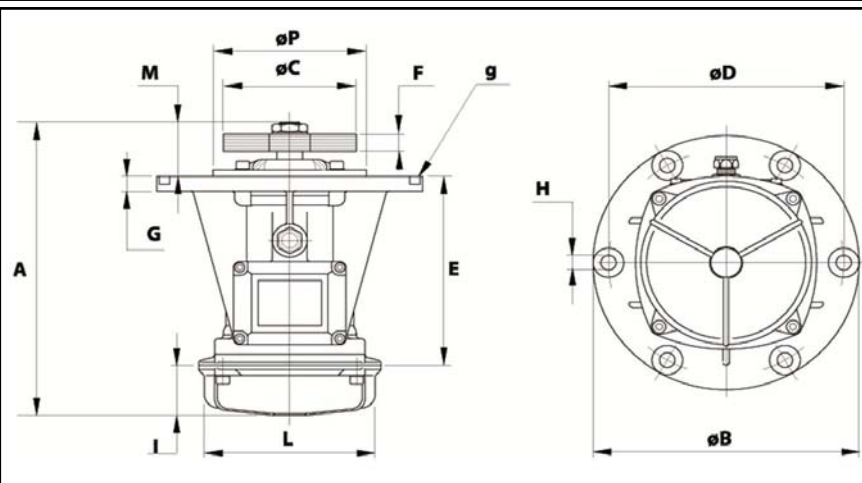

A	279,5
B	245
C	122
D	205
H	12
N° TROUS	6
E	124
F	24 (50Hz) 15 (60Hz)
G	12
I	65
L	145
M	90,5
P	162