

## VIBRATOR TYPE: MTF 15/1100E-S90 260/460 VOLTS THREE PHASES 60 Hz

ACBMV B. CASADIO VIBRATION  
 Z.I. Mi-Plaine  
 51 Rue Ampère  
 B.P. 31  
 69682 CHASSIEU CEDEX (FRANCE)  
 Tel.: 04 78 90 87 87 / Fax.: 04 78 90 87 88  
 Email: [vibrateur@orange.fr](mailto:vibrateur@orange.fr)  
 Internet: [acbmv.com](http://acbmv.com)

4 POLES - 1800 RPM      ATEX II 2G,D - Classe Ex e II T4/T3 tD A21 IP 66 ZONE 1-2 / 21-22  
 REF.: 6E1280C      Gas T°=T3-T4 Dust T°=120°C  
 SIZE: 40

Certifications:



### MECHANICAL AND ELECTRICAL SPECIFICATIONS

Eccentric weight setup (%)	Centrifugal force weight up/down (kg)	Static moment weight	Centrifugal force weight up/down (kN)	Static moment weight up (kgmm)	Estimated bearings life time (hours)
100	491/491	105	4,82/4,82	136	30500
90	441,9/441,9	94,50	4,34/4,34	122,40	43334
80	392,8/392,8	84,00	3,86/3,86	108,80	64170
70	343,7/343,7	73,50	3,37/3,37	95,20	>100000
60	294,6/294,6	63,00	2,89/2,89	81,60	>100000
50	245,5/245,5	52,50	2,41/2,41	68,00	>100000
40	196,4/196,4	42,00	1,93/1,93	54,40	>100000
30	147,3/147,3	31,50	1,45/1,45	40,80	>100000
20	98,2/98,2	21,00	0,96/0,96	27,20	>100000
10	49,1/49,1	10,50	0,48/0,48	13,60	>100000

Power supply (volts)	460
Phases:	three phases
Frequency (Hz)	60 Hz
Rotation speed (RPM)	1800
Max input power (watt)	Input: T3=950 T4=700 Rating: T3=730 T4=505
Max current (amp)	T3=1,32 T4=1
IS/IR	T3=4 T4=5,36

### DIMENSIONAL SPECIFICATIONS (mm)

**Vibrator weight: 31,4 kg**

Continual service ambient temperature: -20°C à +40°C - Tropicalization anti-mold - Mechanical protection: IP66 IK08 according to IEC

Bearing type: ROLLER

Lubrication LONG-LIFE with KLUEBER STABURAGS NBU 8EP.

Re lubrication quantity after 1000 hours of using: 16g

Max quantity by replaced bearing: 9g

Fixing with 6 screws M10 - 7/16" quality 8.8 with tightening torque (kgm - ft/lb): 4.80 - 35

Power supply cable size: 9 à 16 mm - Cable entry thread: M25x1,5

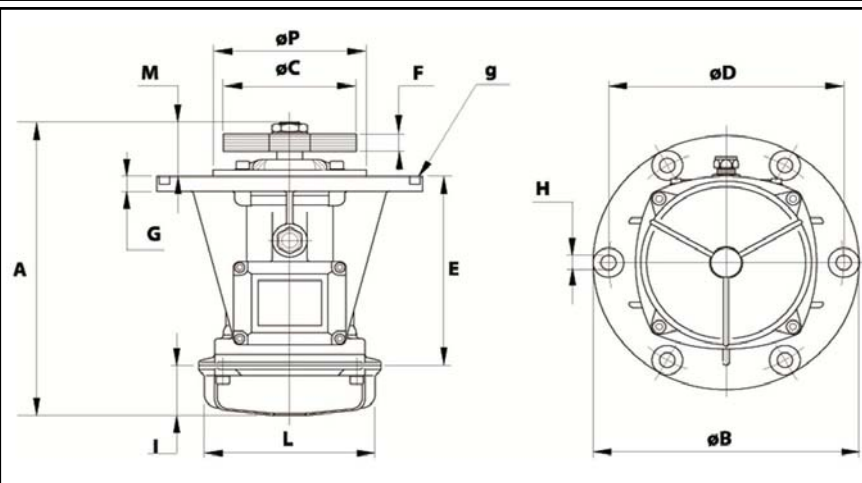

A	426
B	279
C	190
D	254
H	14
N° TROUS	4
E	-
F	49
G	17,5
I	57,5
L	-
M	84,5
P	229