

VIBRATOR TYPE: MTF 15/200 E-S02 260/460 VOLTS THREE PHASES 60 Hz

ACBMV B. CASADIO VIBRATION
 Z.I. Mi-Plaine
 51 Rue Ampère
 B.P. 31
 69682 CHASSIEU CEDEX (FRANCE)
 Tel.: 04 78 90 87 87 / Fax.: 04 78 90 87 88
 Email: vibrateur@orange.fr
 Internet: acbm.com

4 POLES - 1800 RPM ATEX II 2G,D - Classe Ex e II T4/T3 tD A21 IP 66 ZONE 1-2 / 21-22
 REF.: 6E1403C Gas T°=T3-T4 Dust T°=120°C
 SIZE: 10

Certifications:



MECHANICAL AND ELECTRICAL SPECIFICATIONS

Eccentric weight setup (%)	Centrifugal force weight up/down (kg)	Static moment weight	Centrifugal force weight up/down (kN)	Static moment weight up (kgmm)	Estimated bearings life time (hours)
100	107/107	10,5	1,05/1,05	29,6	19200
90	96,3/96,3	9,45	0,95/0,95	26,64	26337
80	85,6/85,6	8,40	0,84/0,84	23,68	37500
70	74,9/74,9	7,35	0,74/0,74	20,72	55977
60	64,2/64,2	6,30	0,63/0,63	17,76	88889
50	53,5/53,5	5,25	0,53/0,53	14,80	>100000
40	42,8/42,8	4,20	0,42/0,42	11,84	>100000
30	32,1/32,1	3,15	0,32/0,32	8,88	>100000
20	21,4/21,4	2,10	0,21/0,21	5,92	>100000
10	10,7/10,7	1,05	0,11/0,11	2,96	>100000

Power supply (volts)	460
Phases:	three phases
Frequency (Hz)	60 Hz
Rotation speed (RPM)	1800
Max input power (watt)	Input: T3=- T4=175 Rating: T3=- T4=95
Max current (amp)	T3=- T4=0,4
IS/IR	T3=2,04 T4=2,34

DIMENSIONAL SPECIFICATIONS (mm)

Vibrator weight: 13,2 kg

Continual service ambient temperature: -20°C à +40°C - Tropicalization anti-mold - Mechanical protection: IP66 IK08 according to IEC

Bearing type: BALL

Lubrication "FOR LIFE" with double protection screen

Fixing with 4 screws M10 - 7/16" quality 8.8 with tightening torque (kgm - ft/lb): 4.80 - 35

Power supply cable size: 6.5 à 12 mm - Cable entry thread: M20x1,5

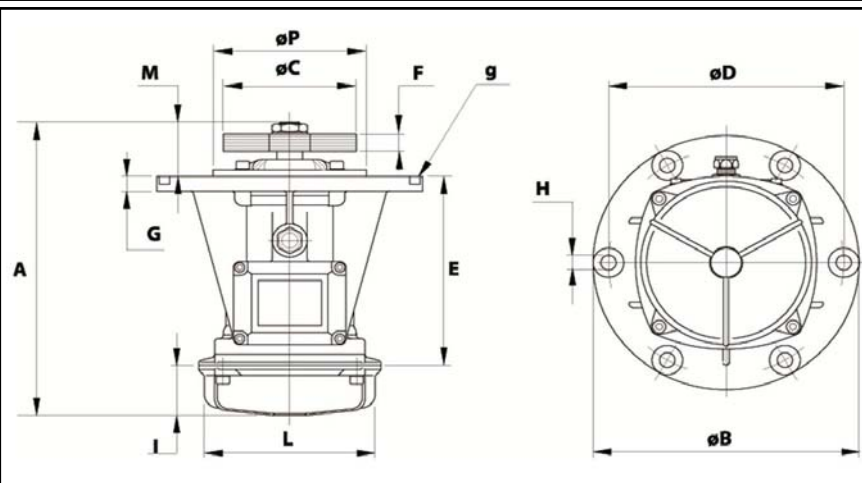

A	292,5
B	215
C	114 (50Hz) 108 (60Hz)
D	187
H	12
N° TROUS	4
E	179,5
F	48 (50Hz) 40 (60Hz)
G	13
I	77
L	127
M	36
P	-