

ACBMV B. CASADIO VIBRATION
 Z.I. Mi-Plaine
 51 Rue Ampère
 B.P. 31
 69682 CHASSIEU CEDEX (FRANCE)
 Tel.: 04 78 90 87 87 / Fax.: 04 78 90 87 88
 Email: vibrateur@orange.fr
 Internet: acbmv.com

4 POLES - 1800 RPM ATEX II 2D tD A21 IP 66 ZONE 21-22
 REF.: 6T1269C Dust T°=135°C
 SIZE: 70

Certifications:



MECHANICAL AND ELECTRICAL SPECIFICATIONS

Eccentric weight setup (%)	Static moment (kgmm)	Working moment (kgcm)	Centrifugal force (kg)	Centrifugal force (kN)	Estimated bearings life time (hours)
100	1173	234,60	4250	41,70	11909
90	1055,70	211,14	3825	37,53	16920
80	938,40	187,68	3400	33,36	25056
70	821,10	164,22	2975	29,19	39103
60	703,80	140,76	2550	25,02	65369
50	586,50	117,30	2125	20,85	>100000
40	469,20	93,84	1700	16,68	>100000
30	351,90	70,38	1275	12,51	>100000
20	234,60	46,92	850	8,34	>100000
10	117,30	23,46	425	4,17	>100000

Power supply (volts)	460
Phases:	three phases
Frequency (Hz)	60 Hz
Rotation speed (RPM)	1800
Max input power (watt)	2800
Max current (amp)	4,65
IS/IR	7,1

DIMENSIONAL SPECIFICATIONS (mm)

Vibrator weight: 117 kg

Continual service ambient temperature: -20°C à +40°C - Tropicalization anti-mold - Mechanical protection: IP66 IK08 according to IEC

Bearing type: ROLLER

Lubrication LONG-LIFE with KLUEBER STABURAGS NBU 8EP.

Re lubrication quantity after 1000 hours of using: 26g

Max quantity by replaced bearing: 40g

Fixing with 4 screws M22 - 7/8" quality 8.8 with tightening torque (kgm - ft/lb): 56 - 411

Power supply cable size: 9 à 16 mm - Cable entry thread: M25x1,5

Maintenance space: 177 mm

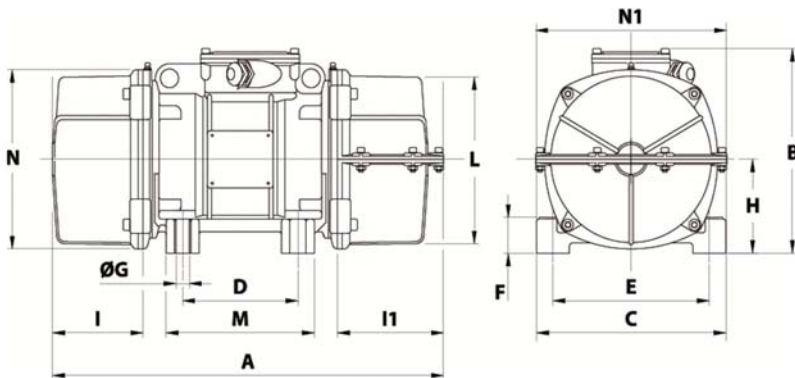

A	1 COVER: 624 / 2 COVERS: 664
B	321
C	310
D	155
E	255
F	77
G	23,5
N° HOLES	4
H	157
I	137
I1	177
N1	326
L	277
M	215
N	295