

ACBMV B. CASADIO VIBRATION  
 Z.I. Mi-Plaine  
 51 Rue Ampère  
 B.P. 31  
 69682 CHASSIEU CEDEX (FRANCE)  
 Tel.: 04 78 90 87 87 / Fax.: 04 78 90 87 88  
 Email: [vibrateur@orange.fr](mailto:vibrateur@orange.fr)  
 Internet: [acbmv.com](http://acbmv.com)

6 POLES - 1200 RPM      ATEX II 2D tD A21 IP 66 ZONE 21-22  
 REF.: 6T2091C              Dust T°=135°C  
 SIZE: 90

Certifications:



### MECHANICAL AND ELECTRICAL SPECIFICATIONS

Eccentric weight setup (%)	Static moment (kgmm)	Working moment (kgcm)	Centrifugal force (kg)	Centrifugal force (kN)	Estimated bearings life time (hours)
100	4055	811,00	6529	64,00	22118
90	3649,50	729,90	5876	57,60	31426
80	3244,00	648,80	5223	51,20	46541
70	2838,50	567,70	4570	44,80	72641
60	2433,00	486,60	3917	38,40	>100000
50	2027,50	405,50	3265	32,00	>100000
40	1622,00	324,40	2612	25,60	>100000
30	1216,50	243,30	1959	19,20	>100000
20	811,00	162,20	1306	12,80	>100000
10	405,50	81,10	653	6,40	>100000

Power supply (volts)	460
Phases:	three phases
Frequency (Hz)	60 Hz
Rotation speed (RPM)	1200
Max input power (watt)	5000
Max current (amp)	8,1
IS/IR	5,83

### DIMENSIONAL SPECIFICATIONS (mm)

**Vibrator weight: 258 kg**

Continual service ambient temperature: -20°C à +40°C - Tropicalization anti-mold - Mechanical protection: IP66 IK08 according to IEC

Bearing type: ROLLER

Lubrication LONG-LIFE with KLUEBER STABURAGS NBU 8EP.

Re lubrication quantity after 1000 hours of using: 60g

Max quantity by replaced bearing: 120g

Fixing with 4 screws M27 - 1" quality 8.8 with tightening torque (kgm - ft/lb): 89 - 645

Power supply cable size: 13 à 20 mm - Cable entry thread: M32x1,5

Maintenance space: 266 mm

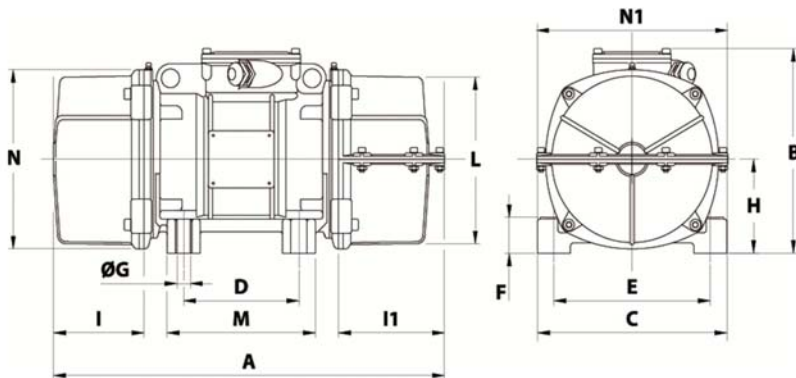

A	1 COVER: 866 / 2 COVERS: 892
B	370
C	390
D	200
E	320
F	90
G	28
N° HOLES	4
H	180
I	240
I1	266
N1	382
L	330
M	270
N	350