

ACBMV B. CASADIO VIBRATION
 Z.I. Mi-Plaine
 51 Rue Ampère
 B.P. 31
 69682 CHASSIEU CEDEX (FRANCE)
 Tel.: 04 78 90 87 87 / Fax.: 04 78 90 87 88
 Email: vibrateur@orange.fr
 Internet: acbmv.com

6 POLES - 1000 RPM ATEX II 2D tD A21 IP 66 ZONE 21-22
 REF.: 6T2143A Dust T°=135°C
 SIZE: 105

Certifications:



MECHANICAL AND ELECTRICAL SPECIFICATIONS

Eccentric weight setup (%)	Static moment (kgmm)	Working moment (kgcm)	Centrifugal force (kg)	Centrifugal force (kN)	Estimated bearings life time (hours)
100	15500	3100,00	17327	170,00	19189
90	13950,00	2790,00	15594	153,00	27265
80	12400,00	2480,00	13862	136,00	40369
70	10850,00	2170,00	12129	119,00	63006
60	9300,00	1860,00	10396	102,00	>100000
50	7750,00	1550,00	8664	85,00	>100000
40	6200,00	1240,00	6931	68,00	>100000
30	4650,00	930,00	5198	51,00	>100000
20	3100,00	620,00	3465	34,00	>100000
10	1550,00	310,00	1733	17,00	>100000

Power supply (volts)	400
Phases:	three phases
Frequency (Hz)	50 Hz
Rotation speed (RPM)	1000
Max input power (watt)	13000
Max current (amp)	24,5
IS/IR	5,71

DIMENSIONAL SPECIFICATIONS (mm)

Vibrator weight: 705,0 kg

Continual service ambient temperature: -20°C à +40°C - Tropicalization anti-mold - Mechanical protection: IP66 IK08 according to IEC

Bearing type: ROLLER

Lubrication LONG-LIFE with KLUEBER STABURAGS NBU 8EP.

Re lubrication quantity after 1000 hours of using: 180g

Max quantity by replaced bearing: 360g

Fixing with 8 screws M42 - 1 5/8" quality 8.8 with tightening torque (kgm - ft/lb): 290 - 2090

Power supply cable size: 13 à 20 mm - Cable entry thread: M32x1,5

Maintenance space: 270 mm

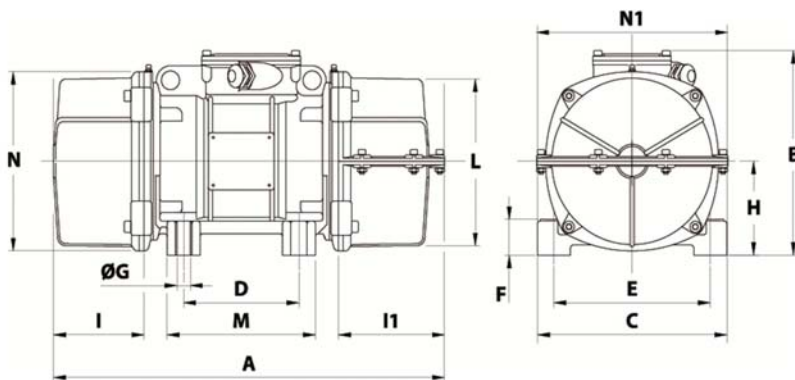

A	1 COVER: 1070 / 2 COVERS: 1100
B	526
C	570
D	140
E	480
F	41
G	45
N° HOLES	8
H	268
I	240
I1	270
N1	566
L	495
M	510
N	516