

ACBMV B. CASADIO VIBRATION
 Z.I. Mi-Plaine
 51 Rue Ampère
 B.P. 31
 69682 CHASSIEU CEDEX (FRANCE)
 Tel.: 04 78 90 87 87 / Fax.: 04 78 90 87 88
 Email: vibrateur@orange.fr
 Internet: acbm.com

6 POLES - 1200 RPM ATEX II 2D tD A21 IP 66 ZONE 21-22
 REF.: 6T2143C Dust T°=135°C
 SIZE: 105

Certifications:



MECHANICAL AND ELECTRICAL SPECIFICATIONS

Eccentric weight setup (%)	Static moment (kgmm)	Working moment (kgcm)	Centrifugal force (kg)	Centrifugal force (kN)	Estimated bearings life time (hours)
100	10439	2087,80	16804	165,00	17711
90	9395,10	1879,02	15124	148,50	25161
80	8351,20	1670,24	13443	132,00	37265
70	7307,30	1461,46	11763	115,50	58151
60	6263,40	1252,68	10082	99,00	97229
50	5219,50	1043,90	8402	82,50	>100000
40	4175,60	835,12	6722	66,00	>100000
30	3131,70	626,34	5041	49,50	>100000
20	2087,80	417,56	3361	33,00	>100000
10	1043,90	208,78	1680	16,50	>100000

Power supply (volts)	460
Phases:	three phases
Frequency (Hz)	60 Hz
Rotation speed (RPM)	1200
Max input power (watt)	19700
Max current (amp)	23
IS/IR	5,96

DIMENSIONAL SPECIFICATIONS (mm)

Vibrator weight: 656 kg

Continual service ambient temperature: -20°C à +40°C - Tropicalization anti-mold - Mechanical protection: IP66 IK08 according to IEC

Bearing type: ROLLER

Lubrication LONG-LIFE with KLUEBER STABURAGS NBU 8EP.

Re lubrication quantity after 1000 hours of using: 180g

Max quantity by replaced bearing: 360g

Fixing with 8 screws M42 - 1 5/8" quality 8.8 with tightening torque (kgm - ft/lb): 290 - 2090

Power supply cable size: 13 à 20 mm - Cable entry thread: M32x1,5

Maintenance space: 270 mm

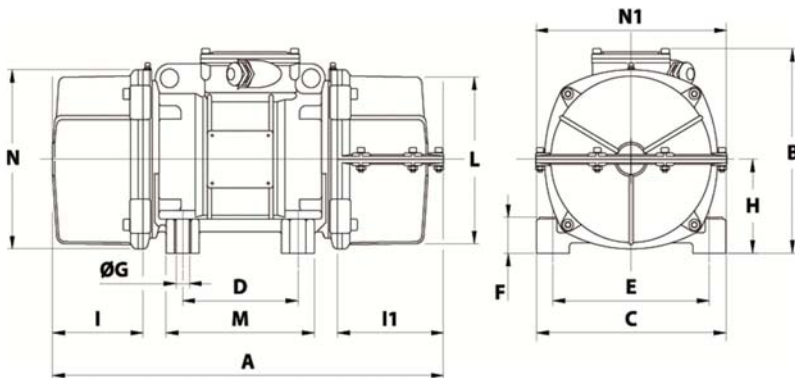

A	1 COVER: 1070 / 2 COVERS: 1100
B	526
C	570
D	140
E	480
F	41
G	45
N° HOLES	8
H	268
I	240
I1	270
N1	566
L	495
M	510
N	516