

ACBMV B. CASADIO VIBRATION  
 Z.I. Mi-Plaine  
 51 Rue Ampère  
 B.P. 31  
 69682 CHASSIEU CEDEX (FRANCE)  
 Tel.: 04 78 90 87 87 / Fax.: 04 78 90 87 88  
 Email: [vibrateur@orange.fr](mailto:vibrateur@orange.fr)  
 Internet: [acbm.com](http://acbm.com)

6 POLES - 1200 RPM      ATEX II 2D tD A21 IP 66 ZONE 21-22  
 REF.: 6T2204C              Dust T°=135°C  
 SIZE: 80

Certifications:



### MECHANICAL AND ELECTRICAL SPECIFICATIONS

Eccentric weight setup (%)	Static moment (kgmm)	Working moment (kgcm)	Centrifugal force (kg)	Centrifugal force (kN)	Estimated bearings life time (hours)
100	2887	577,40	4648	46,00	26335
90	2598,30	519,66	4183	41,40	37422
80	2309,60	461,92	3718	36,80	55427
70	2020,90	404,18	3254	32,20	86436
60	1732,20	346,44	2789	27,60	>100000
50	1443,50	288,70	2324	23,00	>100000
40	1154,80	230,96	1859	18,40	>100000
30	866,10	173,22	1394	13,80	>100000
20	577,40	115,48	930	9,20	>100000
10	288,70	57,74	465	4,60	>100000

Power supply (volts)	460
Phases:	three phases
Frequency (Hz)	60 Hz
Rotation speed (RPM)	1200
Max input power (watt)	3600
Max current (amp)	6
IS/IR	5,5

### DIMENSIONAL SPECIFICATIONS (mm)

**Vibrator weight: 183 kg**

Continual service ambient temperature: -20°C à +40°C - Tropicalization anti-mold - Mechanical protection: IP66 IK08 according to IEC

Bearing type: ROLLER

Lubrication LONG-LIFE with KLUEBER STABURAGS NBU 8EP.

Re lubrication quantity after 1000 hours of using: 40g

Max quantity by replaced bearing: 80g

Fixing with 4 screws M24 - 15/16" quality 8.8 with tightening torque (kgm - ft/lb): 71 - 513

Power supply cable size: 13 à 20 mm - Cable entry thread: M32x1,5

Maintenance space: 259 mm

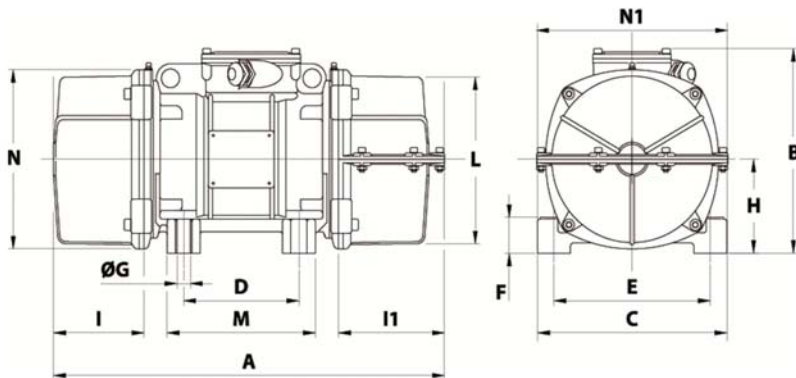

A	1 COVER: 822 / 2 COVERS: 848
B	347
C	340
D	180
E	280
F	80
G	26
N° HOLES	4
H	165
I	233
I1	259
N1	356
L	303
M	240
N	320