

ACBMV B. CASADIO VIBRATION
 Z.I. Mi-Plaine
 51 Rue Ampère
 B.P. 31
 69682 CHASSIEU CEDEX (FRANCE)
 Tel.: 04 78 90 87 87 / Fax.: 04 78 90 87 88
 Email: vibrateur@orange.fr
 Internet: acbmv.com

6 POLES - 1200 RPM ATEX II 2D tD A21 IP 66 ZONE 21-22
 REF.: 6T2351C Dust T°=135°C
 SIZE: 90

Certifications:



MECHANICAL AND ELECTRICAL SPECIFICATIONS

Eccentric weight setup (%)	Static moment (kgmm)	Working moment (kgcm)	Centrifugal force (kg)	Centrifugal force (kN)	Estimated bearings life time (hours)
100	3478	695,60	5600	54,90	18621
90	3130,20	626,04	5040	49,41	26456
80	2782,40	556,48	4480	43,92	39177
70	2434,60	486,92	3920	38,43	61142
60	2086,80	417,36	3360	32,94	>100000
50	1739,00	347,80	2800	27,45	>100000
40	1391,20	278,24	2240	21,96	>100000
30	1043,40	208,68	1680	16,47	>100000
20	695,60	139,12	1120	10,98	>100000
10	347,80	69,56	560	5,49	>100000

Power supply (volts)	460
Phases:	three phases
Frequency (Hz)	60 Hz
Rotation speed (RPM)	1200
Max input power (watt)	4000
Max current (amp)	6,5
IS/IR	5,08

DIMENSIONAL SPECIFICATIONS (mm)

Vibrator weight: 220 kg

Continual service ambient temperature: -20°C à +40°C - Tropicalization anti-mold - Mechanical protection: IP66 IK08 according to IEC

Bearing type: ROLLER

Lubrication LONG-LIFE with KLUEBER STABURAGS NBU 8EP.

Re lubrication quantity after 1000 hours of using: 50g

Max quantity by replaced bearing: 100g

Fixing with 4 screws M27 - 1" quality 8.8 with tightening torque (kgm - ft/lb): 89 - 645

Power supply cable size: 13 à 20 mm - Cable entry thread: M32x1,5

Maintenance space: 266 mm

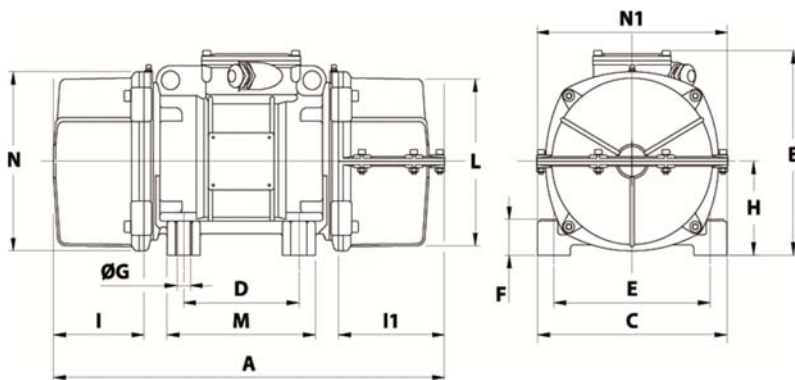

A	1 COVER: 866 / 2 COVERS: 892
B	370
C	390
D	200
E	320
F	90
G	28
N° HOLES	4
H	180
I	240
I1	266
N1	382
L	330
M	270
N	350