

ACBMV B. CASADIO VIBRATION
 Z.I. Mi-Plaine
 51 Rue Ampère
 B.P. 31
 69682 CHASSIEU CEDEX (FRANCE)
 Tel.: 04 78 90 87 87 / Fax.: 04 78 90 87 88
 Email: vibrateur@orange.fr
 Internet: acbmv.com

8 POLES - 750 RPM ATEX II 2D tD A21 IP 66 ZONE 21-22
 REF.: 6T2551A Dust T°=135°C
 SIZE: 97

Certifications:



MECHANICAL AND ELECTRICAL SPECIFICATIONS

Eccentric weight setup (%)	Static moment (kgmm)	Working moment (kgcm)	Centrifugal force (kg)	Centrifugal force (kN)	Estimated bearings life time (hours)
100	7340	1468,00	4616	45,30	>100000
90	6606,00	1321,20	4154	40,77	>100000
80	5872,00	1174,40	3693	36,24	>100000
70	5138,00	1027,60	3231	31,71	>100000
60	4404,00	880,80	2770	27,18	>100000
50	3670,00	734,00	2308	22,65	>100000
40	2936,00	587,20	1846	18,12	>100000
30	2202,00	440,40	1385	13,59	>100000
20	1468,00	293,60	923	9,06	>100000
10	734,00	146,80	462	4,53	>100000

Power supply (volts)	400
Phases:	three phases
Frequency (Hz)	50 Hz
Rotation speed (RPM)	750
Max input power (watt)	5600
Max current (amp)	10,5
IS/IR	3,12

DIMENSIONAL SPECIFICATIONS (mm)

Vibrator weight: 330,0 kg

Continual service ambient temperature: -20°C à +40°C - Tropicalization anti-mold - Mechanical protection: IP66 IK08 according to IEC

Bearing type: ROLLER

Lubrication LONG-LIFE with KLUEBER STABURAGS NBU 8EP.

Re lubrication quantity after 1000 hours of using: 60g

Max quantity by replaced bearing: 120g

Fixing with 6 screws M36 - 1 3/8" quality 8.8 with tightening torque (kgm - ft/lb): 190 - 1370

Power supply cable size: 13 à 20 mm - Cable entry thread: M32x1,5

Maintenance space: 246 mm

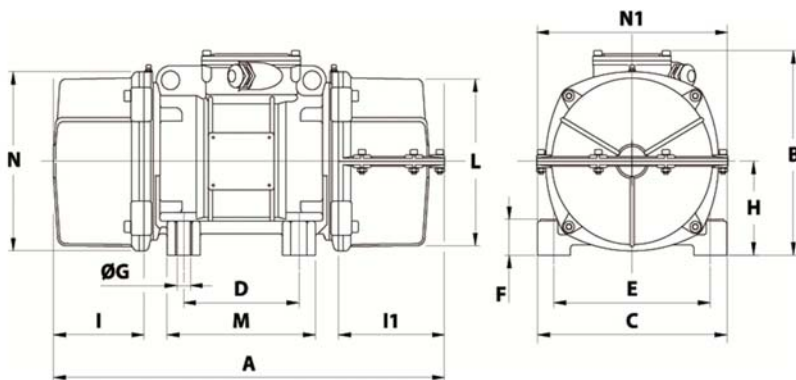

A	1 COVER: 878 / 2 COVERS: 894
B	437
C	460
D	125
E	380
F	35
G	39
N° HOLES	6
H	215
I	230
I1	246
N1	450
L	387
M	320
N	414