

ACBMV B. CASADIO VIBRATION
 Z.I. Mi-Plaine
 51 Rue Ampère
 B.P. 31
 69682 CHASSIEU CEDEX (FRANCE)
 Tel.: 04 78 90 87 87 / Fax.: 04 78 90 87 88
 Email: vibrateur@orange.fr
 Internet: acbmv.com

8 POLES - 900 RPM ATEX II 2D tD A21 IP 66 ZONE 21-22
 REF.: 6T2610C Dust T°=120°C
 SIZE: 50

Certifications:



MECHANICAL AND ELECTRICAL SPECIFICATIONS

Eccentric weight setup (%)	Static moment (kgmm)	Working moment (kgcm)	Centrifugal force (kg)	Centrifugal force (kN)	Estimated bearings life time (hours)
100	1012	202,40	917	9,00	>100000
90	910,80	182,16	825	8,10	>100000
80	809,60	161,92	734	7,20	>100000
70	708,40	141,68	642	6,30	>100000
60	607,20	121,44	550	5,40	>100000
50	506,00	101,20	459	4,50	>100000
40	404,80	80,96	367	3,60	>100000
30	303,60	60,72	275	2,70	>100000
20	202,40	40,48	183	1,80	>100000
10	101,20	20,24	92	0,90	>100000

Power supply (volts)	460
Phases:	three phases
Frequency (Hz)	60 Hz
Rotation speed (RPM)	900
Max input power (watt)	500
Max current (amp)	1,3
IS/IR	2,85

DIMENSIONAL SPECIFICATIONS (mm)

Vibrator weight: 67 kg

Continual service ambient temperature: -20°C à +40°C - Tropicalization anti-mold - Mechanical protection: IP66 IK08 according to IEC

Bearing type: BALL

Lubrication "FOR LIFE" with double protection screen

Fixing with 4 screws M16 - 5/8" quality 8.8 with tightening torque (kgm - ft/lb): 19 - 137

Power supply cable size: 9 à 16 mm - Cable entry thread: M25x1,5

Maintenance space: 192 mm

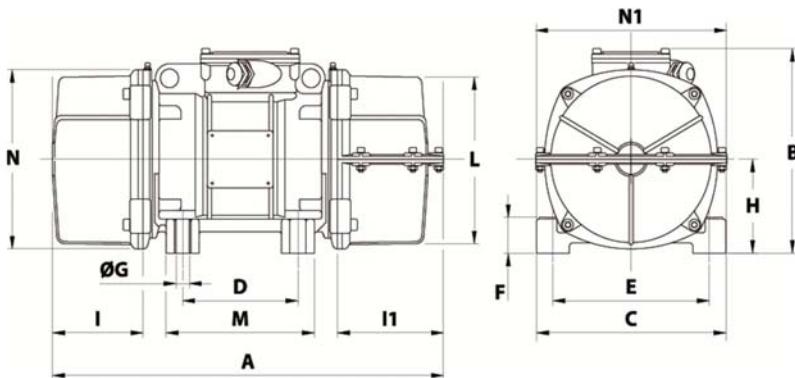

A	1 COVER: 592 / 2 COVERS: 616
B	246
C	230
D	140
E	190
F	54
G	17
N° HOLES	4
H	116
I	168
I1	192
N1	258
L	210
M	180
N	225